

Sunfab By-Pass is a relief valve for the SCP pump providing remote switch-ing between idling and operation.

By-Pass is used in installations where the power take off is not disengaged during transport. These are usually found on vehicles fitted with hydraulic equipment that needs to be manoeuvred while on the move, for example, road maintenance vehicles, concrete mixers, refuse collection trucks, etc.

The By-Pass valve is controlled from the driver's cab and makes it possible to provide oil to the vehicle's hydraulic equipment when necessary. The valve opens a link between the feed line and suction line directly by the pump, which is then offloaded. Only a small amount of oil circulates via the existing system to cool the pump. When a closed-centre valve or a valve with a high circulation pressure is used, a separate cooling line is made as set out in the instructions on the rear of this sheet.

Other advantages of the Sunfab By-Pass valve

- Can also be operated manually, which makes control possible even in the event of a power failure. Automatic emergency function opens the valve with a power failure
- Compact design in steel for direct mounting on the pump's connection cover for small installation dimensions
- 24 V equipment is equipped with an integrated, two metre long power cable, which conforms to the protection class ADR. (International Carriage of Dangerous Goods by Road)
- Can be regulated at 0-40 MPa working pressure in the hydraulic system
- Symmetrical design supports installation of the magnetic valve in different directions, and use on both right and left-hand rotating pumps
- SUNFAB By-Pass is the most versatile by-pass valve available on the market

BY-PASS		SCP 012-064		SCPT 090	SCP 084-108	SCPT 130
Weight	kg	2.4		2.4	3.0	3.0
Max working pressure	MPa	40		40	40	40
Max pump speed	rpm	012-034	040-064	090	084-108	130
		3000	2500	2000	2000	2000
Magnet voltage	V	12 / 24		12 / 24	12 / 24	12 / 24
Current	A	1.88 / 0.52		1.88 / 0.52	1.88 / 0.52	1.88 / 0.52
Power	W	22.5 / 12.5		22.5 / 12.5	22.5 / 12.5	22.5 / 12.5
Protection class contact		IP 66 - / ADR		IP 66 - / ADR	IP 66 - / ADR	IP 66 - / ADR
Function		Normally open		Normally open	Normally open	Normally open
Dimensions	mm	A	45	45	41	41
		B	110	110	127	127
		C	36	36	42	42
		D	G 3/4	G 3/4	G 1	G 1
		E	100	100	116	116
		F	25	25	28	28
		G	31	31	31	31

Subject to design alteration

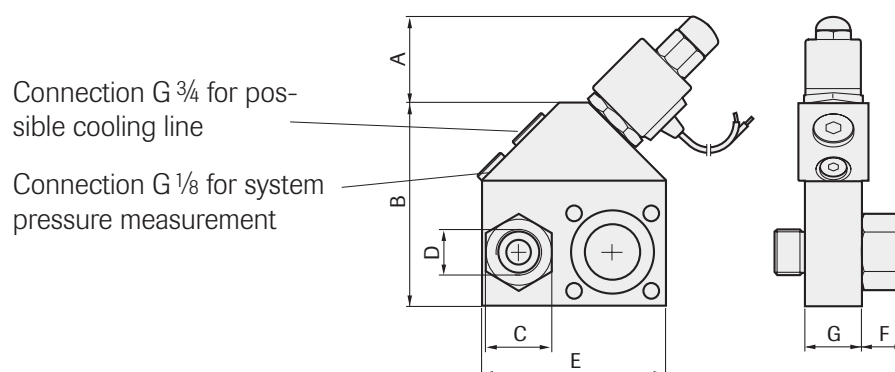

When the hydraulic system is equipped with a closed-centre valve or another type of valve, which has a circulation pressure of 0.15 MPa or more, a separate cooling line must be connected to create oil circulation and cooling of the pump. The connection to the oil tank should be below the oil level.

